

7/8"-4 1/2"  
O.D.

AF3 SERIES

Features :

- Best 'Value For Money' tool in the world when flaring of tube ends is needed.
- Sturdy construction with rolls self contained in cage.
- Time tested, durable design.
- Overlapping flare rolls prevent ridging of tube.
- Use - Economical tool used for applications where small number of tubes are to be expanded with flaring.

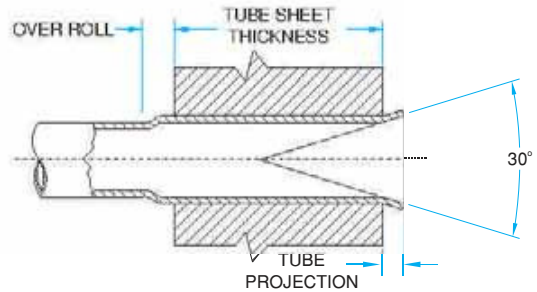
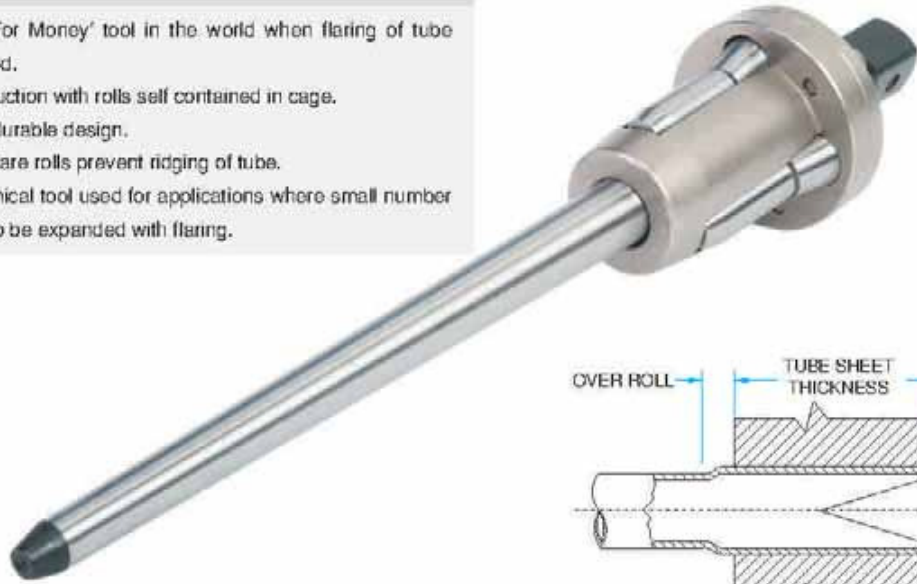

Tube O.D.	Tube Thickness		Tube O.D.	Tube Thickness		Minimum I.D. Tool Enters		Maximum Expansion Of Tool		Tube Expander Model Number Tube Sheet Thickness Range				
	inch	bwg		inch	bwg	mm	inch	mm	inch	1/2" To 7/8"	3/4" To 1.1/8"	1.1/8" To 1.5/8"	1.5/8" To 2.1/8"	2.1/8" To 2.5/8"
7/8	15	.072	1	10	.134	18.1	.712	20.4	.803	AF3-31/2	AF3-31/3	-	-	-
7/8	16	.065				18.4	.724	20.7	.814	AF3-32/2	AF3-32/3	-	-	-
7/8	17	.058	1	11	.120	18.8	.740	21.1	.830	AF3-33/2	AF3-33/3	-	-	-
7/8	18	.049	1	12	.109	19.4	.763	21.6	.850	AF3-34/2	AF3-34/3	-	-	-
7/8	19 & 20	.042 & .035	1.1/8	8	.165	19.7	.775	22.3	.877	AF3-35/2	AF3-35/3	-	-	-
1	13	.095				20.1	.791	22.4	.881	AF3-36/2	AF3-36/3	-	-	-
1	14	.083	1.1/8	9	.148	20.6	.811	23.1	.909	AF3-37/2	AF3-37/3	AF3-37/4	-	-
1	15 & 16	.072 & .065	1.1/8	10	.134	21.3	.838	23.8	.937	AF3-38/2	AF3-38/3	AF3-38/4	-	-
1	17 & 18	.058 & .048	1.1/8	11	.120	22.0	.866	24.5	.964	AF3-39/2	AF3-39/3	AF3-39/4	-	-
1	19 & 20	.042 & .035	1.1/8	12	.109	22.4	.881	25.0	.984	AF3-40/2	AF3-40/3	AF3-40/4	-	-
1.1/4	8	.165	1.1/8	13	.095	23.3	.917	25.9	1.019	AF3-41/2	AF3-41/3	AF3-41/4	-	-
1.1/4	9	.148	1.1/8	14	.083	23.8	.937	26.5	1.043	AF3-42/2	AF3-42/3	AF3-42/4	-	-
1.1/4	10	.134	1.1/8	15 & 16	.072 & .065	24.4	.960	27.2	1.070	AF3-43/2	AF3-43/3	AF3-43/4	-	-
1.1/4	11	.120				25.2	.992	28.0	1.102	AF3-44/2	AF3-44/3	AF3-44/4	-	-
1.1/4	12	.109				25.7	1.011	28.5	1.122	AF3-45/2	AF3-45/3	AF3-45/4	-	-
1.1/4	13	.095	1.3/8	8	.165	26.1	1.027	28.8	1.133	AF3-46/2	AF3-46/3	AF3-46/4	-	-
1.1/4	14	.083				26.4	1.039	29.2	1.149	AF3-47/2	AF3-47/3	AF3-47/4	-	-
1.1/4	15	.072	1.3/8	9	.148	26.9	1.059	29.7	1.169	AF3-48/2	AF3-48/3	AF3-48/4	-	-
1.1/4	16	.065	1.3/8	10	.134	27.6	1.086	30.4	1.196	AF3-49/2	AF3-49/3	AF3-49/4	AF3-49/5	AF3-49/6
1.1/2	7	.180	1.3/8	11	.120	28.3	1.114	31.2	1.228	AF3-50/2	AF3-50/3	AF3-50/4	AF3-50/5	AF3-50/6
1.1/2	8	.165	1.3/8	12	.109	28.8	1.133	31.7	1.248	AF3-51/2	AF3-51/3	AF3-51/4	AF3-51/5	AF3-51/6
1.1/2	9	.148	1.3/8	13 & 14	.095 & .083	29.5	1.161	33.4	1.314	AF3-52/2	AF3-52/3	AF3-52/4	AF3-52/5	AF3-52/6
1.1/2	10	.134	1.3/8	15 & 16	.072 & .065	30.0	1.181	34.1	1.342	AF3-53/2	AF3-53/3	AF3-53/4	AF3-53/5	AF3-53/6
1.1/2	11 & 12	.120 & .109				30.6	1.204	34.8	1.370	AF3-54/2	AF3-54/3	AF3-54/4	AF3-54/5	AF3-54/6
1.1/2	13	.095	1.3/4	5	.220	31.4	1.236	35.6	1.401	AF3-55/2	AF3-55/3	AF3-55/4	AF3-55/5	AF3-55/6
1.1/2	14 & 15	.083 & .072	1.3/4	6	.203	32.6	1.283	36.8	1.448	AF3-56/2	AF3-56/3	AF3-56/4	AF3-56/5	AF3-56/6
			1.3/4	7	.180	33.4	1.314	38.1	1.500	AF3-57/2	AF3-57/3	AF3-57/4	AF3-57/5	AF3-57/6
			1.3/4	8	.165	34.2	1.346	38.7	1.523	AF3-58/2	AF3-58/3	AF3-58/4	AF3-58/5	AF3-58/6
2	3	.259	1.3/4	9 & 10	.148 & .134	35.0	1.377	40.6	1.598	AF3-59/2	AF3-59/3	AF3-59/4	AF3-59/5	AF3-59/6
2	4	.238	1.3/4	11 & 12	.120 & .109	36.6	1.440	42.2	1.661	AF3-60/2	AF3-60/3	AF3-60/4	AF3-60/5	AF3-60/6
2	5 & 6	.220 & .203	1.3/4	13 & 14	.095 & .083	38.2	1.503	43.8	1.712	AF3-61/2	AF3-61/3	AF3-61/4	AF3-61/5	AF3-61/6
2	7 & 8	.180 & .165	1.3/4	15 & 16	.072 & .065	39.8	1.566	45.4	1.787	AF3-62/2	AF3-62/3	AF3-62/4	AF3-62/5	AF3-62/6
2	9 & 10	.148 & .134	2.1/4	3	.259	41.4	1.629	47.0	1.850	AF3-63/2	AF3-63/3	AF3-63/4	AF3-63/5	AF3-63/6
2	11 - 13	.120 - .095	2.1/4	4	.238	42.9	1.688	49.5	1.948	AF3-64/2	AF3-64/3	AF3-64/4	AF3-64/5	AF3-64/6
2	14 - 16	.083 - .065	2.1/4	6 & 7	.203 & .180	44.5	1.751	51.1	2.011	AF3-65/2	AF3-65/3	AF3-65/4	AF3-65/5	AF3-65/6
2	17 & 18	.058 & .049	2.1/4	8 & 9	.165 & .148	46.1	1.814	52.7	2.074	AF3-66/2	AF3-66/3	AF3-66/4	AF3-66/5	AF3-66/6

# AF3 SERIES

7/8" - 4 1/2"  
O.D.

AF3 SERIES

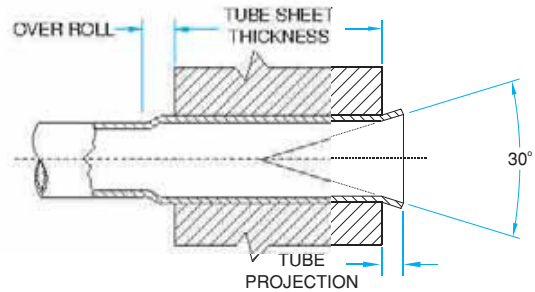
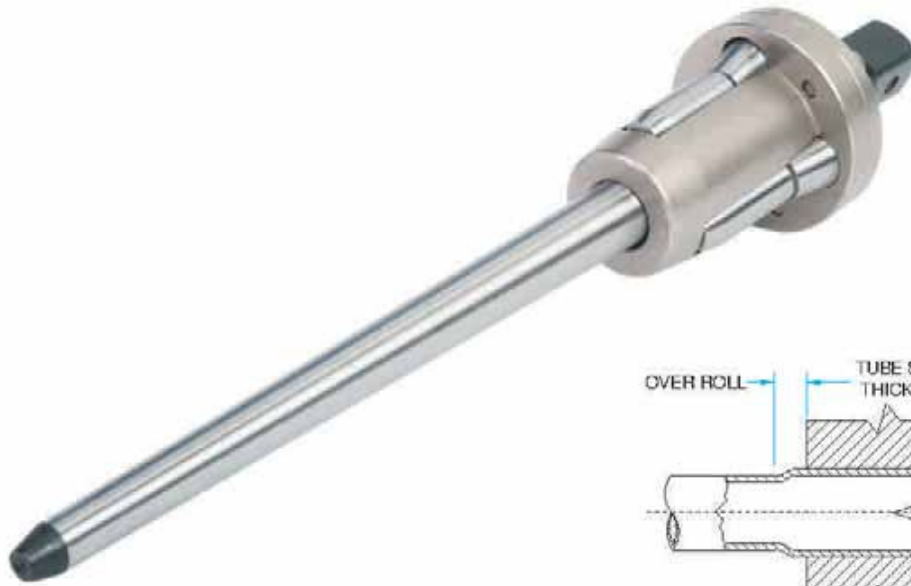

Spare Rollers Set Model Number Tube Sheet Thickness Range					Mandrel Square Drive Size inch	Spare Mandrel Model Number		
1/2" To 7/8"	3/4" To 1.1/8"	1.1/8" To 1.5/8"	1.5/8" To 2.1/8"	2.1/8" To 2.5/8"		Drum Type	Header Type	Short Series Mandrel Set (No. Of Mandrels)
15-2-F3S	15-3-F3S	-	-	-	3/8	DM-11	-	-
15-2-F3S	15-3-F3S	-	-	-	3/8	DM-12	-	-
16-2-F3S	16-3-F3S	-	-	-	3/8	DM-12	-	-
20-2-F3S	20-3-F3S	-	-	-	3/8	DM-12	-	-
17-2-F3S	17-3-F3S	-	-	-	3/8	DM-13	-	-
18-2-F3S	18-3-F3S	-	-	-	3/8	DM-12	-	-
18-2-F3S	18-3-F3S	18-4-F3S	-	-	3/8	DM-13	HM-13	SM-13 (2)
19-2-F3S	19-3-F3S	19-4-F3S	-	-	3/8	DM-13	HM-13	SM-13 (2)
21-2-F3S	21-3-F3S	21-4-F3S	-	-	3/8	DM-13	HM-13	SM-13 (2)
21-2-F3S	21-3-F3S	21-4-F3S	-	-	3/8	DM-14	HM-14	SM-14 (2)
22-2-F3S	22-3-F3S	22-4-F3S	-	-	3/8	DM-14	HM-14	SM-14 (2)
23-2-F3S	23-3-F3S	23-4-F3S	-	-	1/2	DM-15	HM-15	SM-15 (2)
24-2-F3S	24-3-F3S	24-4-F3S	-	-	1/2	DM-15	HM-15	SM-15 (2)
26-2-F3S	26-3-F3S	26-4-F3S	-	-	1/2	DM-16	HM-16	SM-16 (2)
27-2-F3S	27-3-F3S	27-4-F3S	-	-	1/2	DM-16	HM-16	SM-16 (2)
31-2-F3S	31-3-F3S	31-4-F3S	-	-	1/2	DM-16	HM-16	SM-16 (2)
28-2-F3S	28-3-F3S	28-4-F3S	-	-	1/2	DM-17	HM-17	SM-17 (2)
29-2-F3S	29-3-F3S	29-4-F3S	-	-	1/2	DM-17	HM-17	SM-17 (2)
30-2-F3S	30-3-F3S	30-4-F3S	30-5-F3S	30-6-F3S	1/2	DM-17	HM-17	SM-17 (2)
30-2-F3S	30-3-F3S	30-4-F3S	30-5-F3S	30-6-F3S	1/2	DM-18	HM-18	SM-18 (2)
34-2-F3S	34-3-F3S	34-4-F3S	34-5-F3S	34-6-F3S	1/2	DM-18	HM-18	SM-18 (2)
28-2-F3S	28-3-F3S	28-4-F3S	28-5-F3S	28-6-F3S	1/2	DM-20	HM-20	SM-20 (2)
29-2-F3S	29-3-F3S	29-4-F3S	29-5-F3S	29-6-F3S	1/2	DM-20	HM-20	SM-20 (2)
30-2-F3S	30-3-F3S	30-4-F3S	30-5-F3S	30-6-F3S	1/2	DM-20	HM-20	SM-20 (2)
33-2-F3S	33-3-F3S	33-4-F3S	33-5-F3S	33-6-F3S	1/2	DM-20	HM-20	SM-20 (2)
32-2-F3S	32-3-F3S	32-4-F3S	32-5-F3S	32-6-F3S	1/2	DM-21	HM-21	SM-21 (2)
36-2-F3S	36-3-F3S	36-4-F3S	36-5-F3S	36-6-F3S	1/2	DM-21	HM-21	SM-21 (2)
37-2-F3S	37-3-F3S	37-4-F3S	37-5-F3S	37-6-F3S	1/2	DM-21	HM-21	SM-21 (2)
33-2-F3S	33-3-F3S	33-4-F3S	33-5-F3S	33-6-F3S	3/4	DM-22	HM-22	SM-22 (3)
37-2-F3S	37-3-F3S	37-4-F3S	37-5-F3S	37-6-F3S	3/4	DM-22	HM-22	SM-22 (3)
38-2-F3S	38-3-F3S	38-4-F3S	38-5-F3S	38-6-F3S	3/4	DM-22	HM-22	SM-22 (3)
39-2-F3S	39-3-F3S	39-4-F3S	39-5-F3S	39-6-F3S	3/4	DM-22	HM-22	SM-22 (3)
40-2-F3S	40-3-F3S	40-4-F3S	40-5-F3S	40-6-F3S	3/4	DM-22	HM-22	SM-22 (3)
40-2-F3S	40-3-F3S	40-4-F3S	40-5-F3S	40-6-F3S	3/4	DM-23	HM-23	SM-23 (3)
41-2-F3S	41-3-F3S	41-4-F3S	41-5-F3S	41-6-F3S	3/4	DM-23	HM-23	SM-23 (3)
42-2-F3S	42-3-F3S	42-4-F3S	42-5-F3S	42-6-F3S	3/4	DM-23	HM-23	SM-23 (3)

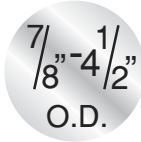

AF3 SERIES

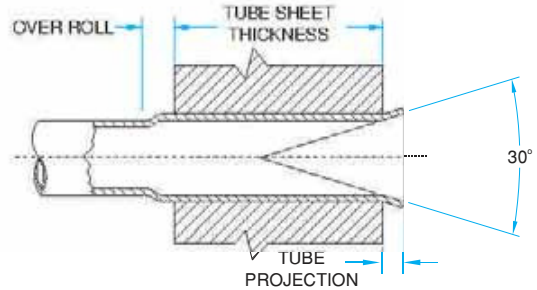
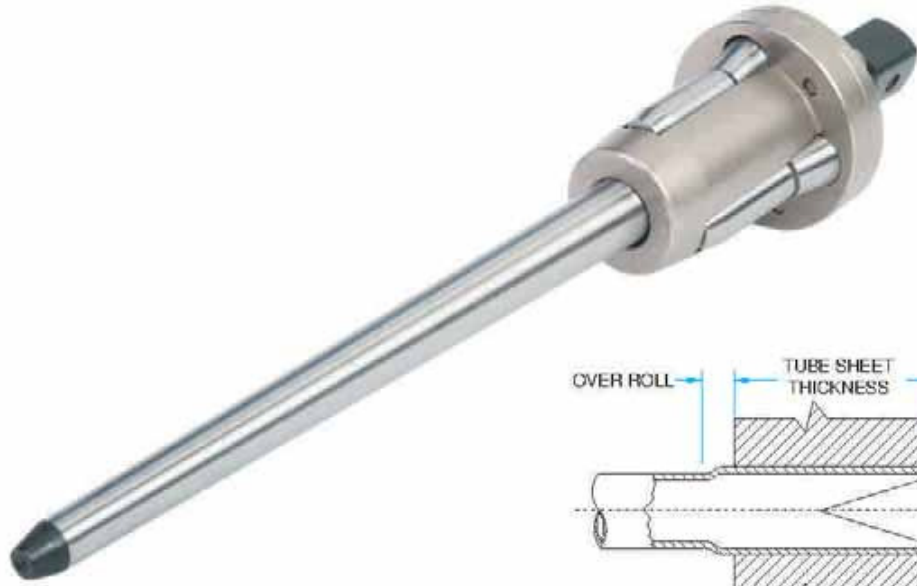

Tube O.D.	Tube Thickness		Tube O.D.	Tube Thickness		Minimum I.D. Tool Enters		Maximum Expansion Of Tool		Tube Expander Model Number Tube Sheet Thickness Range				
	inch	bwg		inch	bwg	inch	mm	inch	mm	inch	1/2" To 7/8"	3/4" To 1.1/8"	1.1/8" To 1.5/8"	1.5/8" To 2.1/8"
2.1/2	3	.259	2.1/4	10 & 11	.134 & .120	47.7	1.877	54.3	2.137	AF3-67/2	AF3-67/3	AF3-67/4	AF3-67/5	AF3-67/6
2.1/2	4 & 5	.238 & .220	2.1/4	12 & 13	.109 & .095	49.3	1.940	55.9	2.200	AF3-68/2	AF3-68/3	AF3-68/4	AF3-68/5	AF3-68/6
2.1/2	6 & 7	.203 & .180	2.1/4	14 - 16	.083 - .065	50.8	2.000	57.8	2.275	AF3-69/2	AF3-69/3	AF3-69/4	AF3-69/5	AF3-69/6
2.1/2	8 & 9	.165 & .148	2.3/4	3	.259	52.4	2.062	59.4	2.338	AF3-70/2	AF3-70/3	AF3-70/4	AF3-70/5	AF3-70/6
2.1/2	10 & 11	.134 & .120	2.3/4	4	.238	54.0	2.125	61.0	2.401	AF3-71/2	AF3-71/3	AF3-71/4	AF3-71/5	AF3-71/6
2.1/2	12 - 14	.109 - .083	2.3/4	5 & 6	.220 & .203	55.6	2.188	64.0	2.519	AF3-72/2	AF3-72/3	AF3-72/4	AF3-72/5	AF3-72/6
2.1/2	15 & 16	.072 & .065	2.3/4	7 & 8	.180 & .165	57.2	2.251	65.6	2.582	AF3-73/2	AF3-73/3	AF3-73/4	AF3-73/5	AF3-73/6
3	3	.259	2.3/4	9 & 10	.148 & .134	58.6	2.307	67.0	2.637	AF3-74/2	AF3-74/3	AF3-74/4	AF3-74/5	AF3-74/6
3	4	.238	2.3/4	11 - 13	.120 - .095	60.4	2.377	68.8	2.708	AF3-75/2	AF3-75/3	AF3-75/4	AF3-75/5	AF3-75/6
3	5 & 6	.220 & .203	2.3/4	14 - 16	.083 - .065	62.2	2.448	70.4	2.771	AF3-76/2	AF3-76/3	AF3-76/4	AF3-76/5	AF3-76/6
3	7 & 8	.180 & .165				63.6	2.503	72.0	2.834	AF3-77/2	AF3-77/3	AF3-77/4	AF3-77/5	AF3-77/6
3	9 & 10	.148 & .134	3.1/4	3	.259	65.0	2.559	73.4	2.889	AF3-78/2	AF3-78/3	AF3-78/4	AF3-78/5	AF3-78/6
3	11 - 13	.120 - .095	3.1/4	4	.238	66.6	2.622	75.0	2.952	AF3-79/2	AF3-79/3	AF3-79/4	AF3-79/5	AF3-79/6
3	14 - 16	.083 - .065	3.1/4	5 & 6	.220 & .203	68.3	2.688	76.9	3.027	AF3-80/2	AF3-80/3	AF3-80/4	AF3-80/5	AF3-80/6
3.1/2	2	.284	3.1/4	7 & 8	.180 & .165	69.9	2.751	78.5	3.090	AF3-81/2	AF3-81/3	AF3-81/4	AF3-81/5	AF3-81/6
3.1/2	3	.259	3.1/4	9 & 10	.148 & .134	71.5	2.814	80.1	3.153	AF3-82/2	AF3-82/3	AF3-82/4	AF3-82/5	AF3-82/6
3.1/2	4	.238	3.1/4	11 - 13	.120 - .095	73.1	2.877	81.7	3.216	AF3-83/2	AF3-83/3	AF3-83/4	AF3-83/5	AF3-83/6
3.1/2	5 & 6	.220 & .203	3.1/4	14 - 16	.083 - .065	74.6	2.937	84.2	3.314	AF3-84/2	AF3-84/3	AF3-84/4	AF3-84/5	AF3-84/6
3.1/2	7 & 8	.180 & .165	3.3/4	2	.284	76.2	3.000	85.5	3.366	AF3-85/2	AF3-85/3	AF3-85/4	AF3-85/5	AF3-85/6
3.1/2	9 - 11	.148 - .120	3.3/4	3	.259	77.8	3.062	87.4	3.440	AF3-86/2	AF3-86/3	AF3-86/4	AF3-86/5	AF3-86/6
3.1/2	12 - 16	.109 - .065	3.3/4	4	.238	79.4	3.125	89.0	3.503	AF3-87/2	AF3-87/3	AF3-87/4	AF3-87/5	AF3-87/6
			3.3/4	5 & 6	.220 & .203	81.0	3.188	90.6	3.566	AF3-88/2	AF3-88/3	AF3-88/4	AF3-88/5	AF3-88/6
4	2	.284	3.3/4	7 & 8	.180 & .165	82.6	3.251	92.2	3.629	AF3-89/2	AF3-89/3	AF3-89/4	AF3-89/5	AF3-89/6
4	3	.259	3.3/4	9 & 10	.148 & .134	84.2	3.314	93.8	3.692	AF3-90/2	AF3-90/3	AF3-90/4	AF3-90/5	AF3-90/6
4	4	.238	3.3/4	11 - 13	.120 - .095	85.8	3.377	96.2	3.787	AF3-91/2	AF3-91/3	AF3-91/4	AF3-91/5	AF3-91/6
4	5 & 6	.220 & .203	3.3/4	14 - 16	.083 - .065	87.4	3.440	97.8	3.850	AF3-92/2	AF3-92/3	AF3-92/4	AF3-92/5	AF3-92/6
4	7 & 8	.180 & .165	4.1/4	2	.284	89.0	3.503	99.4	3.913	AF3-93/2	AF3-93/3	AF3-93/4	AF3-93/5	AF3-93/6
4	9 - 11	.148 - .120	4.1/4	3	.259	90.4	3.559	100.8	3.968	AF3-94/2	AF3-94/3	AF3-94/4	AF3-94/5	AF3-94/6
4	12 - 16	.109 - .065	4.1/4	4	.238	92.0	3.622	102.4	4.031	AF3-95/2	AF3-95/3	AF3-95/4	AF3-95/5	AF3-95/6
			4.1/4	5 & 6	.220 & .203	93.4	3.677	103.8	4.086	AF3-96/2	AF3-96/3	AF3-96/4	AF3-96/5	AF3-96/6
4.1/2	2	.284	4.1/4	7 & 8	.180 & .165	95.0	3.740	105.4	4.149	AF3-97/2	AF3-97/3	AF3-97/4	AF3-97/5	AF3-97/6
4.1/2	3	.259	4.1/4	9 - 11	.148 - .120	96.6	3.803	107.0	4.212	AF3-98/2	AF3-98/3	AF3-98/4	AF3-98/5	AF3-98/6
4.1/2	4 & 5	.238 & .220	4.1/4	11 - 13	.120 - .095	98.2	3.866	108.6	4.275	AF3-99/2	AF3-99/3	AF3-99/4	AF3-99/5	AF3-99/6
4.1/2	6 & 7	.203 & .180				101.2	3.984	110.0	4.330	AF3-100/2	AF3-100/3	AF3-100/4	AF3-100/5	AF3-100/6
4.1/2	8 & 9	.165 & .148				102.8	4.047	111.6	4.393	AF3-101/2	AF3-101/3	AF3-101/4	AF3-101/5	AF3-101/6
4.1/2	10 - 12	.134 - .109				104.4	4.110	113.2	4.456	AF3-102/2	AF3-102/3	AF3-102/4	AF3-102/5	AF3-102/6

# AF3 SERIES

7/8" - 4 1/2"  
O.D.

AF3 SERIES

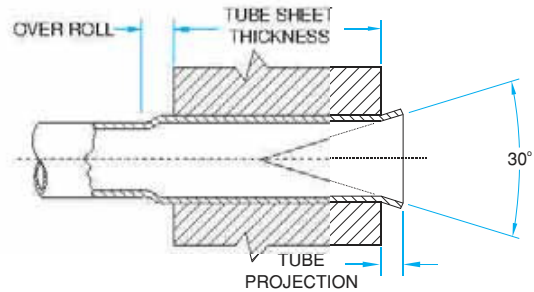
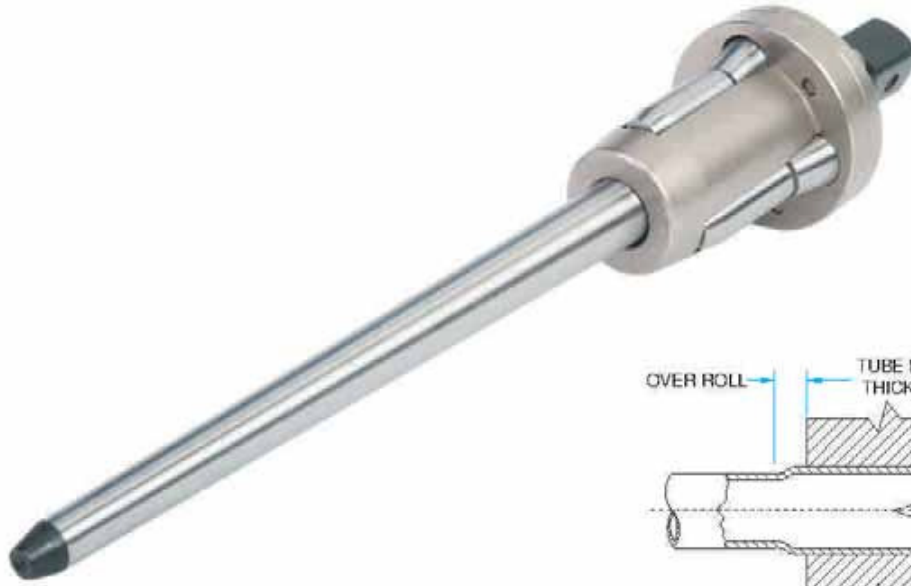

Spare Rollers Set Model Number Tube Sheet Thickness Range					Mandrel Square Drive Size inch	Spare Mandrel Model Number		
1/2" To 7/8"	3/4" To 1.1/8"	1.1/8" To 1.5/8"	1.5/8" To 2.1/8"	2.1/8" To 2.5/8"		Drum Type	Header Type	Short Series Mandrel Set (No. Of Mandrels)
43-2-F3S	43-3-F3S	43-4-F3S	43-5-F3S	43-6-F3S	3/4	DM-23	HM-23	SM-23 (3)
44-2-F3S	44-3-F3S	44-4-F3S	44-5-F3S	44-6-F3S	3/4	DM-23	HM-23	SM-23 (3)
43-2-F3S	43-3-F3S	43-4-F3S	43-5-F3S	43-6-F3S	3/4	DM-24	HM-24	SM-24 (3)
44-2-F3S	44-3-F3S	44-4-F3S	44-5-F3S	44-6-F3S	3/4	DM-24	HM-24	SM-24 (3)
45-2-F3S	45-3-F3S	45-4-F3S	45-5-F3S	45-6-F3S	3/4	DM-24	HM-24	SM-24 (3)
47-2-F3S	47-3-F3S	47-4-F3S	47-5-F3S	47-6-F3S	3/4	DM-24	HM-24	SM-24 (3)
46-2-F3S	46-3-F3S	46-4-F3S	46-5-F3S	46-6-F3S	1	DM-25	HM-25	SM-25 (3)
47-2-F3S	47-3-F3S	47-4-F3S	47-5-F3S	47-6-F3S	1	DM-25	HM-25	SM-25 (3)
48-2-F3S	48-3-F3S	48-4-F3S	48-5-F3S	48-6-F3S	1	DM-25	HM-25	SM-25 (3)
49-2-F3S	49-3-F3S	49-4-F3S	49-5-F3S	49-6-F3S	1	DM-25	HM-25	SM-25 (3)
50-2-F3S	50-3-F3S	50-4-F3S	50-5-F3S	50-6-F3S	1	DM-25	HM-25	SM-25 (3)
51-2-F3S	51-3-F3S	51-4-F3S	51-5-F3S	51-6-F3S	1	DM-25	HM-25	SM-25 (3)
52-2-F3S	52-3-F3S	52-4-F3S	52-5-F3S	52-6-F3S	1	DM-25	HM-25	SM-25 (3)
51-2-F3S	51-3-F3S	51-4-F3S	51-5-F3S	51-6-F3S	1	DM-26	HM-26	SM-26 (4)
52-2-F3S	52-3-F3S	52-4-F3S	52-5-F3S	52-6-F3S	1	DM-26	HM-26	SM-26 (4)
53-2-F3S	53-3-F3S	53-4-F3S	53-5-F3S	53-6-F3S	1	DM-26	HM-26	SM-26 (4)
54-2-F3S	54-3-F3S	54-4-F3S	54-5-F3S	54-6-F3S	1	DM-26	HM-26	SM-26 (4)
54-2-F3S	54-3-F3S	54-4-F3S	54-5-F3S	54-6-F3S	1	DM-27	HM-27	SM-27 (4)
55-2-F3S	55-3-F3S	55-4-F3S	55-5-F3S	55-6-F3S	1	DM-27	HM-27	SM-27 (4)
56-2-F3S	56-3-F3S	56-4-F3S	56-5-F3S	56-6-F3S	1	DM-27	HM-27	SM-27 (4)
57-2-F3S	57-3-F3S	57-4-F3S	57-5-F3S	57-6-F3S	1	DM-27	HM-27	SM-27 (4)
58-2-F3S	58-3-F3S	58-4-F3S	58-5-F3S	58-6-F3S	1	DM-27	HM-27	SM-27 (4)
59-2-F3S	59-3-F3S	59-4-F3S	59-5-F3S	59-6-F3S	1	DM-27	HM-27	SM-27 (4)
60-2-F3S	60-3-F3S	60-4-F3S	60-5-F3S	60-6-F3S	1	DM-27	HM-27	SM-27 (4)
59-2-F3S	59-3-F3S	59-4-F3S	59-5-F3S	59-6-F3S	1	DM-28	HM-28	SM-28 (4)
60-2-F3S	60-3-F3S	60-4-F3S	60-5-F3S	60-6-F3S	1	DM-28	HM-28	SM-28 (4)
61-2-F3S	61-3-F3S	61-4-F3S	61-5-F3S	61-6-F3S	1	DM-28	HM-28	SM-28 (4)
62-2-F3S	62-3-F3S	62-4-F3S	62-5-F3S	62-6-F3S	1	DM-28	HM-28	SM-28 (4)
63-2-F3S	63-3-F3S	63-4-F3S	63-5-F3S	63-6-F3S	1	DM-28	HM-28	SM-28 (4)
62-2-F3S	62-3-F3S	62-4-F3S	62-5-F3S	62-6-F3S	1	DM-29	HM-29	SM-29 (4)
63-2-F3S	63-3-F3S	63-4-F3S	63-5-F3S	63-6-F3S	1	DM-29	HM-29	SM-29 (4)
64-2-F3S	64-3-F3S	64-4-F3S	64-5-F3S	64-6-F3S	1	DM-29	HM-29	SM-29 (4)
63-2-F3S	63-3-F3S	63-4-F3S	63-5-F3S	63-6-F3S	1	DM-30	HM-30	SM-30 (4)
64-2-F3S	64-3-F3S	64-4-F3S	64-5-F3S	64-6-F3S	1	DM-30	HM-30	SM-30 (4)
65-2-F3S	65-3-F3S	65-4-F3S	65-5-F3S	65-6-F3S	1	DM-30	HM-30	SM-30 (4)
66-2-F3S	66-3-F3S	66-4-F3S	66-5-F3S	66-6-F3S	1	DM-30	HM-30	SM-30 (4)