

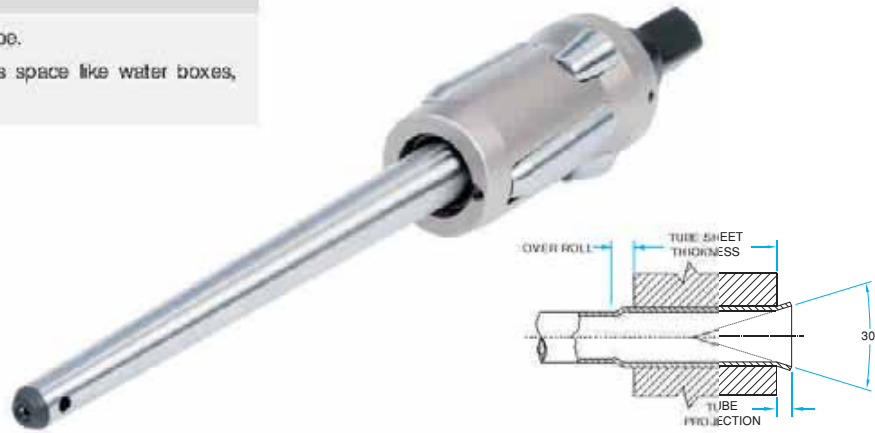

P-1000 SERIES

Features :

- Overlapping rolls prevent ridging of tube.
- Use - Ideal for use in limited access space like water boxes, small diameter drums.



Tube O.D.	Tube Thickness		Tube O.D.	Tube Thickness		Minimum I.D. Tool Enters		Maximum Expansion Of Tool		Tube Expander Model Number Tube Sheet Thickness Range				
	inch	bwg		inch	bwg	inch	mm	inch	mm	inch	1/2" To 3/4"	7/8" To 1.1/4"	1.3/8" To 1.3/4"	1.7/8" To 2.1/4"
1	13 & 14	.095 & .083	1.1/8	9	.148	19.7	.775	23.4	.921	P1079/3	P1079/5	-	-	-
1	15 & 16	.072 & .065	1.1/8	10	.134	20.7	.814	24.4	.961	P1083/3	P1083/5	-	-	-
1.1/4	7	.180	1.1/8	11 & 12	.120 & .109	21.7	.854	25.5	1.004	P1087/3	P1087/5	-	-	-
1.1/4	8 & 9	.165 & .148	1.1/8	13 & 14	.095 & .083	22.7	.893	26.5	1.043	P1091/3	P1091/5	-	-	-
1.1/4	10	.134	1.1/8	15 & 16	.072 & .065	23.7	.933	28.1	1.105	P1095/3	P1095/5	-	-	-
1.1/4	11 - 13	.120 - .095	1.3/8	8	.165	24.7	.972	29.0	1.142	P1099/3	P1099/5	-	-	-
1.1/4	14 & 15	.083 & .072	1.3/8	9	.148	25.7	1.011	30.0	1.181	P1103/3	P1103/5	-	-	-
1.1/4	16	.065	1.3/8	10	.134	27.8	1.094	33.0	1.299	P1111/3	P1111/5	-	-	-
1.1/2	10 - 12	.134 - .109	1.3/8	15 & 16	.072 & .065	30.7	1.208	35.0	1.378	P1118/3	P1118/5	-	-	-
1.1/2	13 - 16	.095 - .065	1.3/4	6 & 7	.203 & .180	32.7	1.287	38.0	1.496	P1126/3	P1126/5	-	-	-
2	3	.259	1.3/4	8 & 9	.165 & .148	34.7	1.366	40.0	1.575	P1134/3	P1134/5	P1134/7	P1134/9	P1134/11
2	4 & 5	.238 & .220	1.3/4	10 - 12	.134 - .109	36.7	1.444	42.5	1.673	P1142/3	P1142/5	P1142/7	P1142/9	P1142/11
2	6	.203	1.3/4	13 - 16	.096 - .065	38.7	1.523	44.5	1.752	P1150/3	P1150/5	P1150/7	P1150/9	P1150/11
2	7 - 9	.180 - .148	2.1/4	3	.259	40.7	1.602	47.0	1.850	P1158/3	P1158/5	P1158/7	P1158/9	P1158/11
2	10 - 12	.134 - .109	2.1/4	4	.238	42.7	1.681	49.0	1.929	P1166/3	P1166/5	P1166/7	P1166/9	P1166/11
2	13 - 15	.095 - .072	2.1/4	5 & 6	.220 & .203	44.7	1.760	51.5	2.027	P1174/3	P1174/5	P1174/7	P1174/9	P1174/11
2	16	.065	2.1/4	7 - 9	.180 - .148	46.7	1.838	54.0	2.126	P1181/3	P1181/5	P1181/7	P1181/9	P1181/11
2.1/2	4 & 5	.238 & .220	2.1/4	10 - 13	.134 - .095	48.7	1.917	56.0	2.205	P1189/3	P1189/5	P1189/7	P1189/9	P1189/11
2.1/2	6	.203	2.1/4	14 - 16	.083 - .065	50.7	1.996	60.0	2.362	P1197/3	P1197/5	P1197/7	P1197/9	P1197/11
2.1/2	7 - 10	.180 - .134	2.3/4	2 & 3	.284 & .259	52.7	2.074	62.0	2.441	P1205/3	P1205/5	P1205/7	P1205/9	P1205/11
2.1/2	11 - 13	.120 - .095	2.3/4	4 & 5	.238 & .220	54.7	2.153	64.0	2.520	P1213/3	P1213/5	P1213/7	P1213/9	P1213/11
2.1/2	14 - 16	.083 - .065	2.3/4	6 - 8	.203 - .165	56.7	2.232	66.0	2.598	P1221/3	P1221/5	P1221/7	P1221/9	P1221/11
3	2	.284	2.3/4	7 - 9	.180 - .148	58.7	2.311	68.0	2.677	P1229/3	P1229/5	P1229/7	P1229/9	P1229/11
3	3 & 4	.259 & .238	2.3/4	10 - 12	.134 - .109	60.7	2.389	70.0	2.756	P1237/3	P1237/5	P1237/7	P1237/9	P1237/11
3	5 & 6	.220 & .203	2.3/4	13 - 16	.095 - .065	62.7	2.468	72.0	2.835	P1244/3	P1244/5	P1244/7	P1244/9	P1244/11
3	7 & 8	.180 & .165				64.7	2.547	74.0	2.913	P1252/3	P1252/5	P1252/7	P1252/9	P1252/11
3	10 - 12	.134 - .109	3.1/4	3	.259	66.7	2.625	76.0	2.992	P1260/3	P1260/5	P1260/7	P1260/9	P1260/11
3	13 & 14	.095 & .083	3.1/4	4	.238	68.7	2.704	78.0	3.071	P1268/3	P1268/5	P1268/7	P1268/9	P1268/11
3	15 & 16	.072 & .065	3.1/4	5 & 6	.220 & .203	70.7	2.783	80.0	3.150	P1276/3	P1276/5	P1276/7	P1276/9	P1276/11
3.1/2	2 & 3	.284 & .259	3.1/4	7 - 11	.180 - .120	72.7	2.862	82.0	3.228	P1284/3	P1284/5	P1284/7	P1284/9	P1284/11
3.1/2	4 - 6	.259 - .203	3.1/4	12 - 14	.109 - .480	74.7	2.940	84.0	3.307	P1292/3	P1292/5	P1292/7	P1292/9	P1292/11
3.1/2	7 - 9	.180 - .148	3.1/4	15 & 16	.072 & .065	76.7	3.019	86.0	3.386	P1300/3	P1300/5	P1300/7	P1300/9	P1300/11
3.1/2	10 - 12	.134 - .109	3.3/4	2 & 3	.284 & .259	78.7	3.098	88.0	3.465	P1308/3	P1308/5	P1308/7	P1308/9	P1308/11
3.1/2	13 - 15	.095 - .072	3.3/4	4 - 6	.259 - .203	80.7	3.177	92.0	3.622	P1315/3	P1315/5	P1315/7	P1315/9	P1315/11
3.1/2	16	.065	3.3/4	7 & 8	.180 & .165	82.7	3.255	94.0	3.701	P1323/3	P1323/5	P1323/7	P1323/9	P1323/11
4	3	.259	3.3/4	9 - 12	.148 - .109	84.7	3.334	96.0	3.780	P1331/3	P1331/5	P1331/7	P1331/9	P1331/11
4	4 - 6	.259 - .203	3.3/4	13 - 16	.095 - .065	86.7	3.413	98.0	3.858	P1339/3	P1339/5	P1339/7	P1339/9	P1339/11
4	7 & 8	.180 & .165	4.1/4	2	.284	88.7	3.492	100.0	3.937	P1347/3	P1347/5	P1347/7	P1347/9	P1347/11
4	9 - 12	.148 - .109	4.1/4	3	.259	90.7	3.570	102.0	4.016	P1355/3	P1355/5	P1355/7	P1355/9	P1355/11
4	13 - 15	.095 - .072	4.1/4	4	.238	92.7	3.649	104.0	4.094	P1363/3	P1363/5	P1363/7	P1363/9	P1363/11
4	16	.065	4.1/4	7 & 8	.180 & .165	94.7	3.728	106.0	4.173	P1370/3	P1370/5	P1370/7	P1370/9	P1370/11
4.1/2	3	.259	4.1/4	9 - 11	.148 - .120	96.7	3.807	108.0	4.252	P1378/3	P1378/5	P1378/7	P1378/9	P1378/11
4.1/2	4 - 6	.259 - .203	4.1/4	12 - 16	.109 - .065	98.7	3.885	110.0	4.331	P1386/3	P1386/5	P1386/7	P1386/9	P1386/11
4.1/2	7 - 14	.180 - .083				100.7	3.964	111.0	4.407	P1394/3	P1394/5	P1394/7	P1394/9	P1394/11

P-1000 SERIES

1" - 4 1/2"
O.D.

P-1000 SERIES

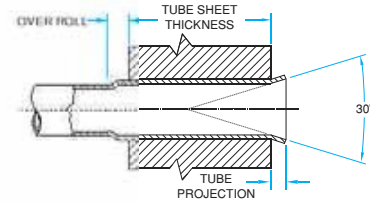

Spare Rollers Set Model Number Tube Sheet Thickness Range					Mandrel Square Drive Size inch	Spare Mandrel Model Number	
1/2" To 3/4"	7/8" To 1.1/4"	1.3/8" To 1.3/4"	1.7/8" To 2.1/4"	2.3/8" To 2.3/4"		Drum Type	Short Series Mandrels
079-3-FS	079-5-FS	-	-	-	1/2	83-MP	-
083-3-FS	083-5-FS	-	-	-	1/2	83-MP	-
087-3-FS	087-5-FS	-	-	-	1/2	91-MP	-
095-3-FS	095-5-FS	-	-	-	1/2	91-MP	-
095-3-FS	095-5-FS	-	-	-	1/2	99-MP	-
099-3-FS	099-5-FS	-	-	-	1/2	99-MP	-
103-3-FS	103-5-FS	-	-	-	1/2	99-MP	-
111-3-FS	111-5-FS	-	-	-	3/4	118-MP	MPS-1,2,3
118-3-FS	118-5-FS	-	-	-	3/4	118-MP	MPS-1,2,3
126-3-FS	126-5-FS	-	-	-	3/4	126-MP	MPS-2,3,4
126-3-FS	126-5-FS	126-7-FS	126-9-FS	126-11-FS	3/4	134-MP	MPS-3,4,5
142-3-FS	142-5-FS	142-7-FS	142-9-FS	142-11-FS	3/4	150-MP	MPS-3,4,5,6
150-3-FS	150-5-FS	150-7-FS	150-9-FS	150-11-FS	3/4	150-MP	MPS-3,4,5,6
158-3-FS	158-5-FS	158-7-FS	158-9-FS	158-11-FS	3/4	174-MP	MPS-4,5,6,7,8
166-3-FS	166-5-FS	166-7-FS	166-9-FS	166-11-FS	3/4	174-MP	MPS-4,5,6,7,8
174-3-FS	174-5-FS	174-7-FS	174-9-FS	174-11-FS	3/4	174-MP	MPS-4,5,6,7,8
181-3-FS	181-5-FS	181-7-FS	181-9-FS	181-11-FS	1	197-MP	MPS-7,8,9,10,11
174-3-FS	174-5-FS	174-7-FS	174-9-FS	174-11-FS	1	197-MP	MPS-7,8,9,10,11
205-3-FS	205-5-FS	205-7-FS	205-9-FS	205-11-FS	1	197-MP	MPS-6,7,8,9,10,11
205-3-FS	205-5-FS	205-7-FS	205-9-FS	205-11-FS	1	221-MP	MPS-7,8,9,10,11,12
213-3-FS	213-5-FS	213-7-FS	213-9-FS	213-11-FS	1	221-MP	MPS-7,8,9,10,11,12
221-3-FS	221-5-FS	221-7-FS	221-9-FS	221-11-FS	1	221-MP	MPS-7,8,9,10,11,12
221-3-FS	221-5-FS	221-7-FS	221-9-FS	221-11-FS	1	244-MP	MPS-8,9,10,11,12,13
237-3-FS	237-5-FS	237-7-FS	237-9-FS	237-11-FS	1	244-MP	MPS-8,9,10,11,12,13
252-3-FS	252-5-FS	252-7-FS	252-9-FS	252-11-FS	1	244-MP	MPS-8,9,10,11,12,13
252-3-FS	252-5-FS	252-7-FS	252-9-FS	252-11-FS	1	268-MP	MPS-10,11,12,13,14
260-3-FS	260-5-FS	260-7-FS	260-9-FS	260-11-FS	1	268-MP	MPS-10,11,12,13,14
268-3-FS	268-5-FS	268-7-FS	268-9-FS	268-11-FS	1	268-MP	MPS-10,11,12,13,14
276-3-FS	276-5-FS	276-7-FS	276-9-FS	276-11-FS	1	300-MP	MPS-12,13,14,15,16
284-3-FS	284-5-FS	284-7-FS	284-9-FS	284-11-FS	1	300-MP	MPS-12,13,14,15,16
292-3-FS	292-5-FS	292-7-FS	292-9-FS	292-11-FS	1	300-MP	MPS-12,13,14,15,16
315-3-FS	315-5-FS	315-7-FS	315-9-FS	315-11-FS	1	300-MP	MPS-12,13,14,15,16
284-3-FS	284-5-FS	284-7-FS	284-9-FS	284-11-FS	1	347-MP	MPS-15,16,17,18,19
315-3-FS	315-5-FS	315-7-FS	315-9-FS	315-11-FS	1	347-MP	MPS-14,15,16,17,18,19
323-3-FS	323-5-FS	323-7-FS	323-9-FS	323-11-FS	1	347-MP	MPS-14,15,16,17,18,19
331-3-FS	331-5-FS	331-7-FS	331-9-FS	331-11-FS	1	347-MP	MPS-14,15,16,17,18,19
355-3-FS	355-5-FS	355-7-FS	355-9-FS	355-11-FS	1	347-MP	MPS-14,15,16,17,18,19
363-3-FS	363-5-FS	363-7-FS	363-9-FS	363-11-FS	1	347-MP	MPS-14,15,16,17,18,19
355-3-FS	355-5-FS	355-7-FS	355-9-FS	355-11-FS	1	394-MP	MPS-17,18,19,20,21
363-3-FS	363-5-FS	363-7-FS	363-9-FS	363-11-FS	1	394-MP	MPS-17,18,19,20,21
370-3-FS	370-5-FS	370-7-FS	370-9-FS	370-11-FS	1	394-MP	MPS-17,18,19,20,21
378-3-FS	378-5-FS	378-7-FS	378-9-FS	378-11-FS	1	394-MP	MPS-17,18,19,20,21
386-3-FS	386-5-FS	386-7-FS	386-9-FS	386-11-FS	1	394-MP	MPS-17,18,19,20,21
394-3-FS	394-5-FS	394-7-FS	394-9-FS	394-11-FS	1	394-MP	MPS-17,18,19,20,21