

1/4" - 3/8"  
O.D.

AN SERIES

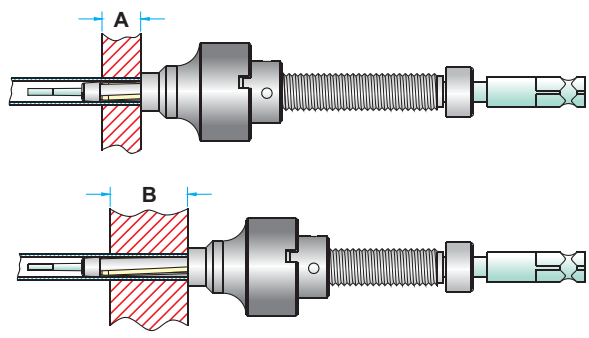

FOR TUBES INTERNAL DIAMETER  
FROM (3.8 mm) .152" TO (8.4 mm) .331"

TUBE EXPANDER FITTED WITH ROLLER LENGTH	FOR TUBE SHEET ADJUSTABLE RANGE	
	MINIMUM A	MAXIMUM B
(25.4mm) 1"	(6.35mm) 1/4"	(25.4mm) 1"

- Use : Oil Coolers, Radiators and other apparatus with small diameter tubes.
- Advantages : Captive mandrel - eliminates nut on mandrel tip which prevents scratching of tube I.D.
- Increased feed angle makes it the fastest operating tool on the market, ideal for high production environments.

Tube O.D. (mm) inch	Tube Thickness			Tube I.D.		Minimum I.D. Tool Enters		Maximum Expansion of Tool		EXPANDER with (25.4 mm) 1" Long Rollers		
	bwg	mm	inch	mm	inch	mm	inch	mm	inch	Complete Tool No.	Mandrel No.	Rollers Set. No.
6.35 1/4	18	1.24	.049	3.8	.152	3.7	.148	4.2	.167	A-25018	M-21819	R-20018
	19	1.06	.042	4.2	.166	4.0	.160	4.5	.180	A-25019	M-21819	R-21920
	20	0.88	.035	4.5	.180	4.4	.175	4.9	.196	A-25020	M-22021	R-21920
	21	0.81	.032	4.7	.186	4.5	.180	5.1	.202	A-25021	M-22021	R-22124
	22	0.71	.028	4.9	.194	4.8	.190	5.4	.213	A-25022	M-20022	R-22124
	23	0.63	.025	5.0	.200	4.9	.195	5.5	.216	A-25023	M-22324	R-21920
	24	0.55	.022	5.2	.206	5.1	.201	5.7	.224	A-25024	M-22324	R-22124
	28	0.35	.014	5.6	.222	5.4	.217	6.1	.243	A-25028	M-22830	R-22830
	29	0.33	.013	5.7	.224	5.4	.217	6.1	.243	A-25028	M-22830	R-22830
30	0.30	.012	5.7	.226	5.4	.217	6.1	.243	A-25028	M-22830	R-22830	
9.53 3/8	14	2.10	.083	5.3	.209	5.1	.204	5.8	.230	A-37514	M-22830-B	R-21920
	15	1.82	.072	5.8	.231	5.6	.225	6.6	.265	A-37515	M-22830-B	R-31516
	16	1.65	.065	6.2	.245	6.0	.238	7.0	.278	A-37516	M-31617	R-31516
	17	1.47	.058	6.5	.259	6.4	.253	7.4	.293	A-37517	M-31617	R-31720
	18	1.24	.049	7.0	.277	6.8	.270	7.8	.310	A-37518	M-30018	R-31720
	19	1.06	.042	7.3	.291	7.1	.285	8.1	.325	A-37519	M-30019	R-31720
	20	0.88	.035	7.7	.305	7.4	.295	8.4	.335	A-37520	M-32021	R-31720
	21	0.81	.032	7.9	.311	7.5	.305	8.6	.345	A-37521	M-32021	R-32122
	22	0.71	.028	8.1	.319	7.9	.312	8.9	.353	A-37522	M-32224	R-32122
23	0.63	.025	8.2	.325	8.1	.318	9.2	.363	A-37523	M-32224	R-32324	
24	0.55	.022	8.4	.331	8.1	.318	9.2	.363	A-37523	M-32224	R-32324	

Note : All 'AN' series expanders come with 1/4" square mandrel drives. Round mandrel drives are optional.